

Filter Receiver - SL



Appcon side loading filter receivers are uniquely designed to fit limited space pneumatic conveying and dust control applications. Our modular design accommodates numerous process configurations.



3004SLFR-HT08A

Available in a variety of finishes including:

- Food Grade
- USDA-3A Dairy
- Advanced Food Grade
- Plastics
- Chemicals
- Nutraceuticals
- Heavy Duty Industrial

Other Options:

- Support frames
- Surge hoppers
- Vibratory/Pneumatic hopper agitation
- Integrated load cell kits
- System controls for complete process automation
- Custom configurations to fit your process

Pneumatic Conveying Options:

- Vacuum
- Pressure
- Dilute Phase
- Semi-Dense Phase
- Dense Phase

Discharge Configurations:

- Integrated hopper
- Full diameter flange
- Butterfly valve
- Airlock for continuous discharge
- Live bottom bin dischargers



Filter Receiver – SL

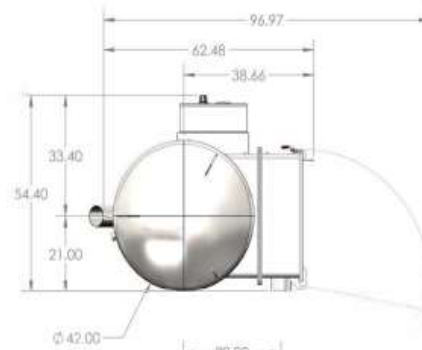
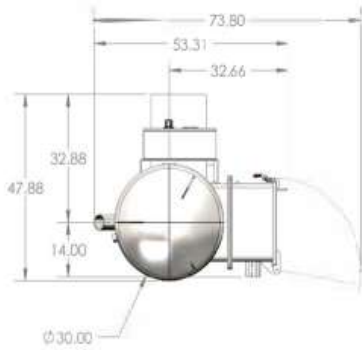

3004SLFR-HT08A

4216SLFR-HT08B

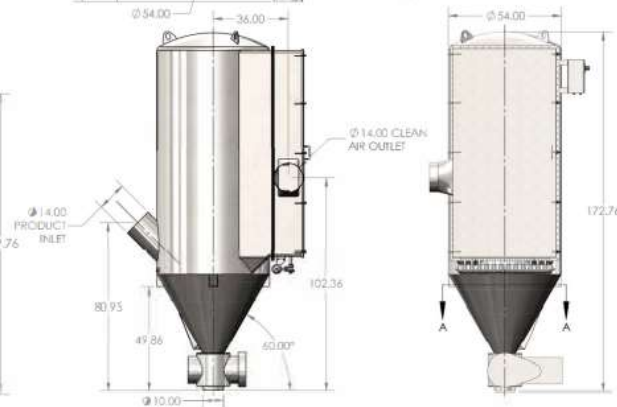
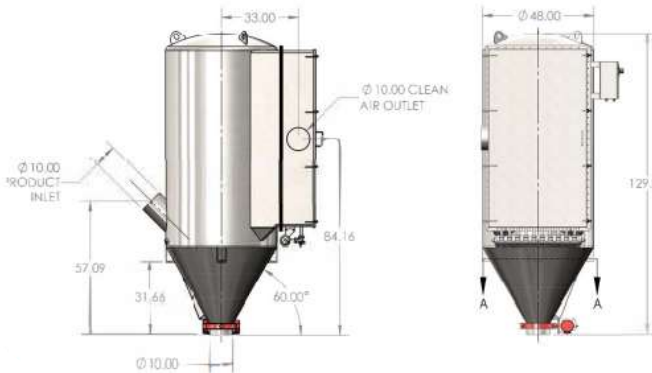
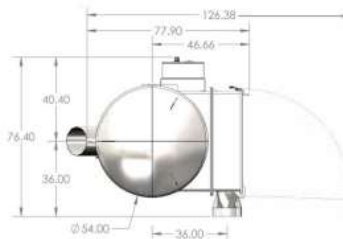
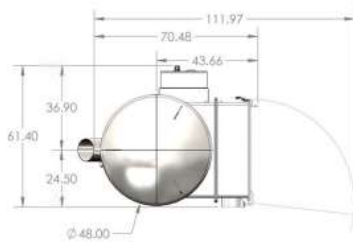

4830SLFR-HT10B

5448SLFR-HT10A