

Filter Receiver - BL



Appcon bottom loading filter receivers are the perfect fit for pneumatic conveying applications. Bottom loading filter media allows tool-free filter access, and our modular design accommodates many process configurations.



2407BLFR08B

Appcon filter receivers are available with a variety of finishes including:

- Food Grade
- USDA Sanitary/Dairy
- Plastics
- Chemicals
- Nutraceuticals



2407BLFR08B

Other Filter Receiver Options:

- Support frames
- Clean air plenum access doors or viewing ports
- Surge hoppers
- Vibratory/Pneumatic hopper agitation
- Integrated load cell kits
- System controls for complete process automation
- Custom configurations to fit your process

Pneumatic Conveying Options:

- ✓ Vacuum
- ✓ Pressure
- ✓ Dilute phase
- ✓ Semi-dense phase
- ✓ Dense phase

Discharge Configurations:

- ✓ Integrated hopper
- ✓ Full diameter flange
- ✓ Butterfly valve
- ✓ Slide gate valve
- ✓ Airlock for continuous discharge

Filter Receiver – BL

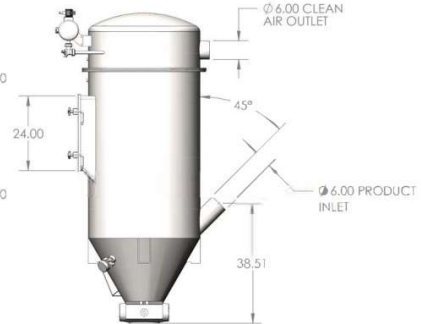
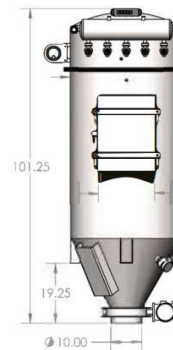
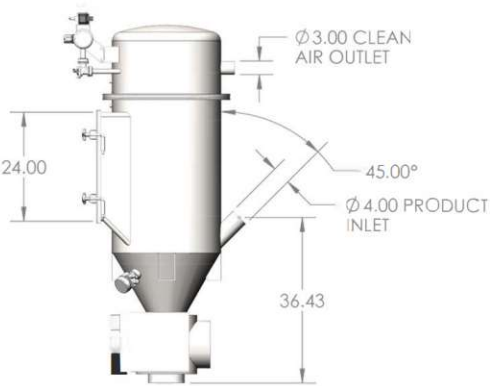
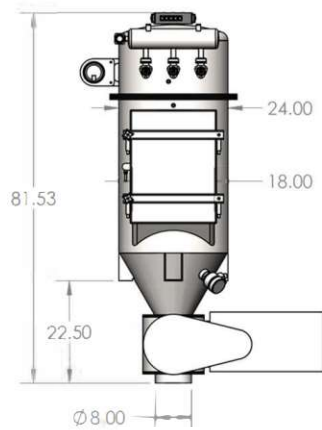
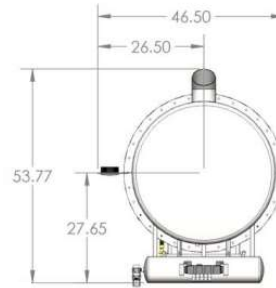
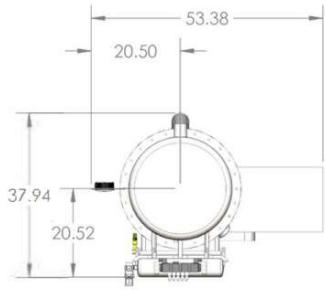

2407BLFR08A

3619BLFR10B

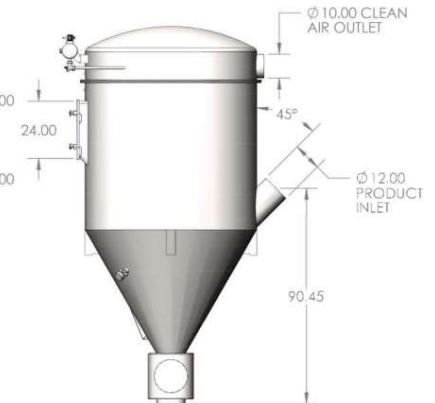
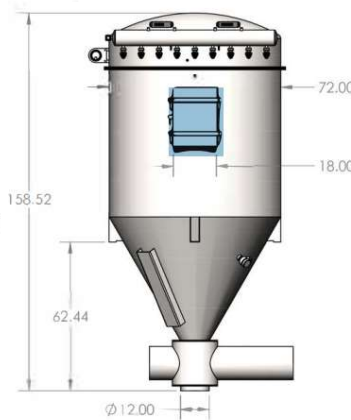
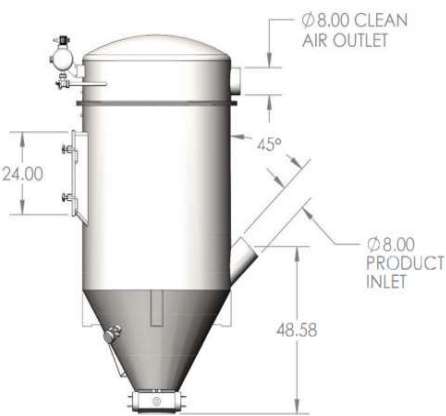
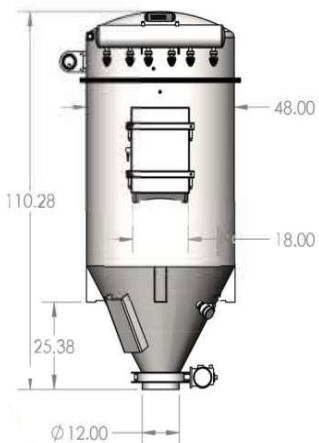
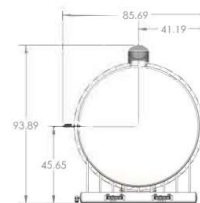
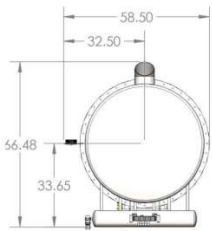

4828BLFR12B

7261BLFR12A

Filter Receiver – BL

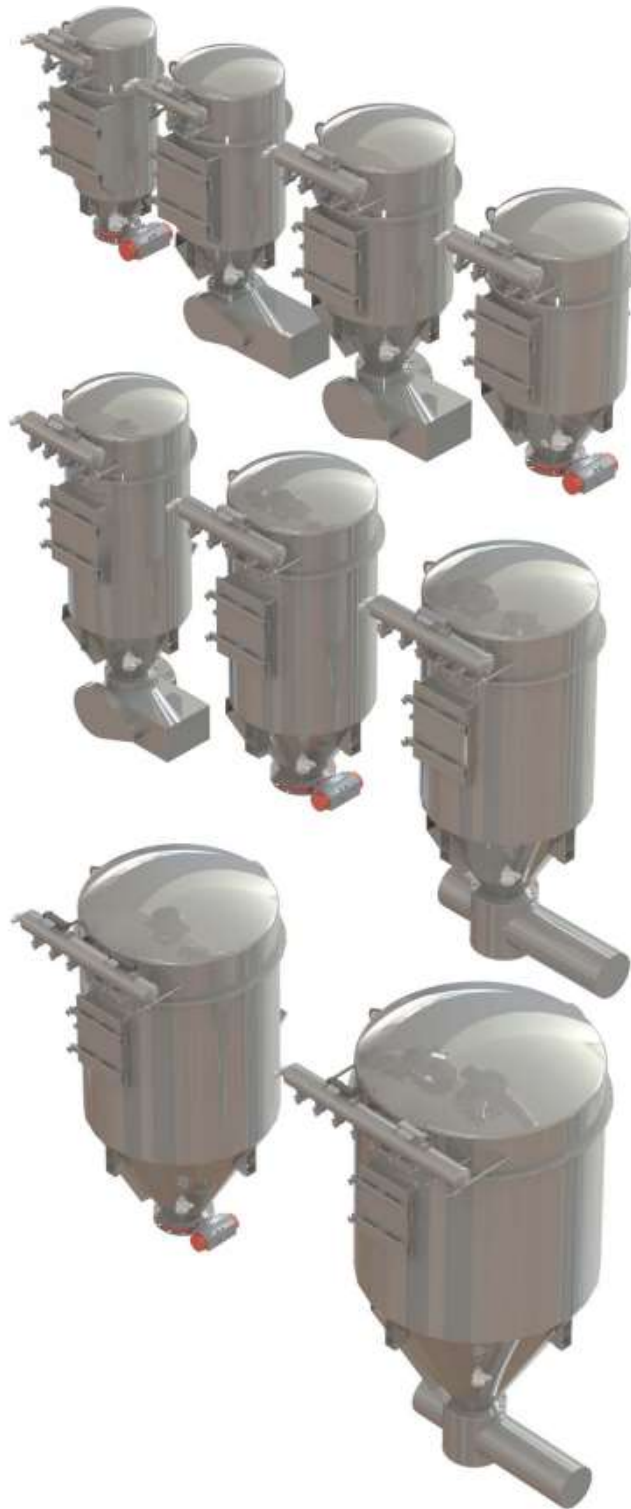

572 Tamarack Ave, Long Lake, MN 55356

(612) 662-4499

sales@appconvey.com