

# FEEDERS AND SCREW CONVEYORS

Appcon specializes in engineering and building hygienic, robust, state-of-the-art feeders and screw conveyors. Our team builds screw conveyors and feeders designed to convey, feed, and meter a variety of materials in a wide range of applications including but not limited to:

- Basic Conveying
- Metering/Feeding for Loss-in-Weight
- Cooling or Heating
- Mixing



## Available with a variety of finishes including:

- Food Grade
- Advanced Food Grade
- USDA-3A Dairy
- Plastics
- Chemicals
- Nutraceuticals
- Heavy Duty Industrial

## Benefits and Features:

- Quick take apart models that can be easily unassembled without the use of tools
- Wide variety of flight pitch options
- Inclined models available
- Twin screw conveyors for bulk silo and larger bin discharging
- Air purged shaft seals
- Flush mounted drop bottom access doors for easy cleaning and inspection
- Belt, direct, and chain drive configurations available
- Tube and Li-trough designs
- Jacketed conveyors with heating and cooling
- Integrated portable bases
- Continuous weldment of flighting to center shaft

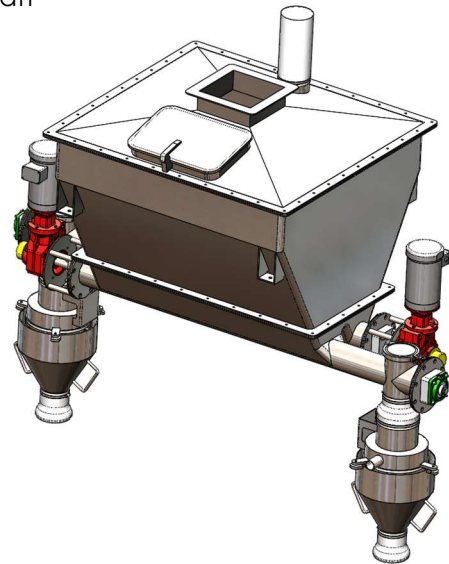

## Appcon offers:

- A comprehensive range of standard and custom feeders and screw conveyors
- Basic units for general industrial applications in painted steel construction
- Sophisticated, sanitary stainless-steel constructions for more demanding applications