

# Appcon Feeders

Appcon designs volumetric and gravimetric feeders that are ideal for feeding bulk pellets, powders, flakes, granules, and much more. Our line of feeders are equipped with numerous features that make them the ideal solution for your dry bulk product feeding or metering application.



## Sanitary Construction:

- Appcon feeders are designed considering the most stringent sanitary requirements. Welds and fit-and-finish are executed to the highest of standards.

## Modular Design – Process Flexibility:

- Appcon feeders are designed to be modular, allowing simple, cost-effective retrofitting of the equipment. The simple, robust nature of their design allows for compatibility with many different applications.

## Features and Benefits:

- Feed rates more than 1000 CfH
- Typical accuracies of +/- 1 to 2% in gravimetric applications, accuracies of up to 0.5% in some applications, 3 to 5% accuracies for volumetric applications
- 316/304 stainless steel or powder coated mild steel construction options
- Variety of hopper agitation options
- Feed augers in open flight or center rod configurations
- Feed augers with variety of pitch configurations
- Extension hoppers
- Quick and easy disassembly
- Floor or hanging mounts available
- Platform scale or load cells utilized for weighing
- Fully integrated turn-key systems with automation
- Non-proprietary parts/hardware
- numerous drive configurations, standard is 230/460/3/60

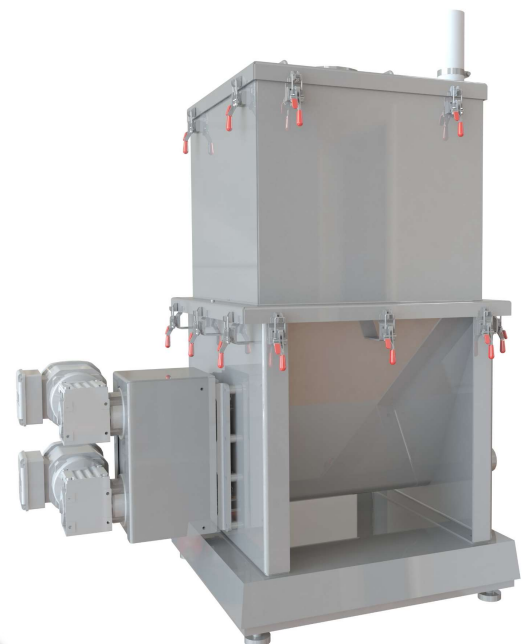

# Appcon Feeders

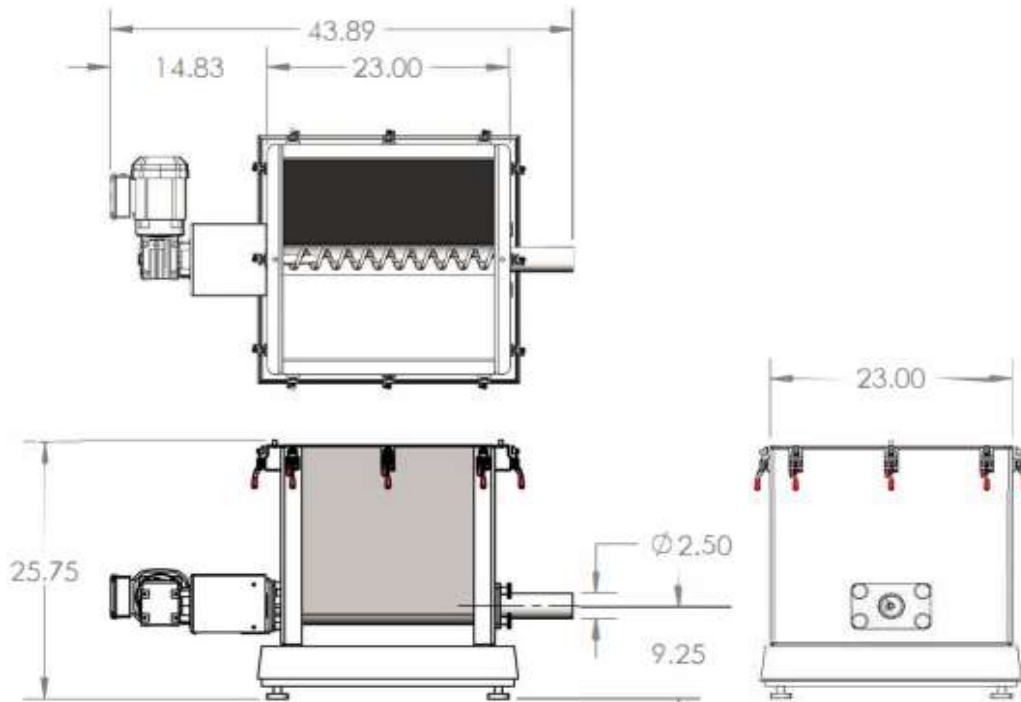

V120-00 - Standard 2"

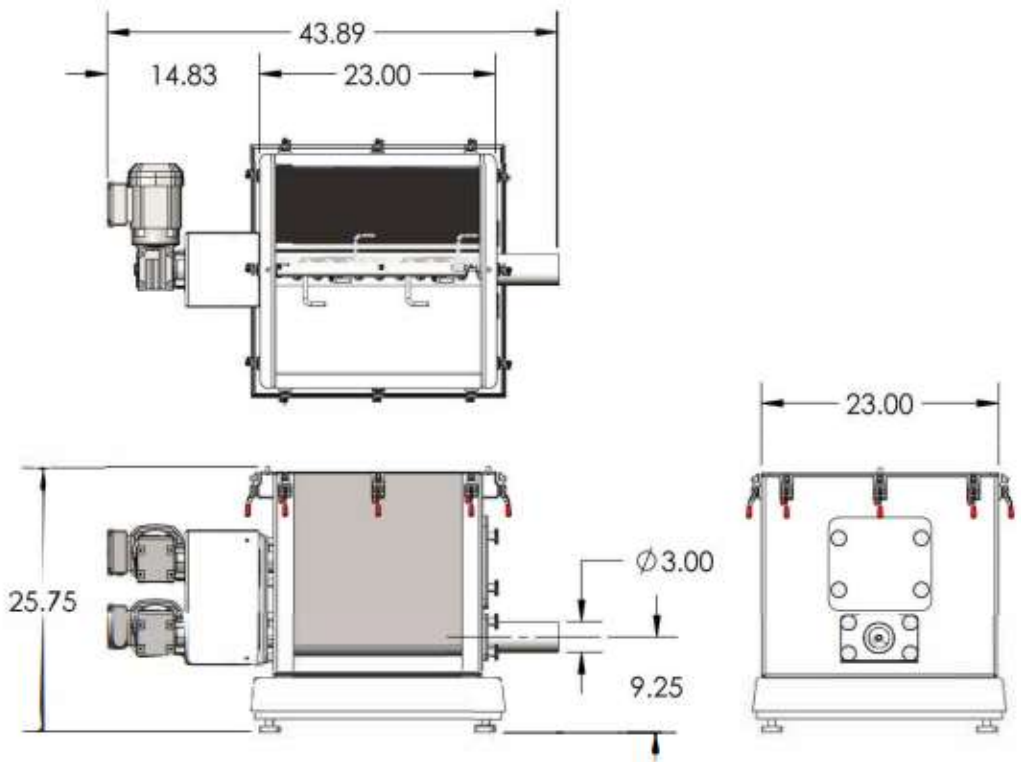

V121-00 - Agitated 2"